

- DS-2CE17U8T-IT
- DS-2CE18U8T-IT3

# TurboHD 4K Series Bullet Camera User Manual

Thank you for purchasing our product. If there are any questions or requests, do not hesitate to contact the dealer.

This manual applies to the models below:

Type	Model
Type I Camera	DS-2CE17U8T-IT
Type II Camera	DS-2CE18U8T-IT3

This manual may contain technical incorrect places or printing errors, and the content is subject to change without notice. The updates will be added to the new version of this manual. We will readily improve or update the products or procedures described in the manual.

## 1 Preface

---

### 1.1 Regulatory Information

#### 1.1.1 FCC Information

Please take attention that changes or modification not expressly approved by the party responsible for compliance could void the user's authority to operate the equipment.

**FCC Compliance:** This equipment has been tested and found to comply with the limits for a Class A digital device, pursuant to part 15 of the FCC Rules. These limits are designed to provide reasonable protection against harmful interference when the equipment is operated in a commercial environment. This equipment generates, uses, and can radiate radio frequency energy and, if not installed and used in accordance with the instruction manual, may cause harmful interference to radio communications. Operation of this equipment in a residential area is likely to cause harmful interference, in which case the user will be required to correct the interference at his own expense.

### 1.1.2 FCC Conditions

This device complies with part 15 of the FCC Rules. Operation is subject to the following two conditions:

1. This device may not cause harmful interference.
2. This device must accept any interference received, including interference that may cause undesired operation.

### 1.1.3 EU Conformity Statement

 This product and, if applicable, the supplied accessories too are marked with “CE” and comply therefore with the applicable harmonized European standards listed under the Low Voltage Directive 2014/35/EU, the EMC Directive



2012/19/EU (WEEE Directive): Products marked with this symbol cannot be disposed of as unsorted municipal waste in the European Union. For proper recycling, return this product to your local supplier upon the purchase of equivalent new equipment, or dispose of it at designated collection points. For more information see: [www.recyclethis.info](http://www.recyclethis.info).



2006/66/EC (Battery Directive): This product contains a battery that cannot be disposed of as unsorted municipal waste in the European Union. See the product documentation for specific battery information. The battery is marked with this symbol, which may include lettering to indicate cadmium (Cd), lead (Pb), or mercury (Hg). For proper recycling, return the battery to your supplier or to a designated collection point. For more information see: [www.recyclethis.info](http://www.recyclethis.info).

### 1.1.4 Industry Canada ICES-003 Compliance

This device meets the CAN ICES-3 (A)/NMB-3(A) standards requirements.



### 1.1.5 Safety Instruction

These instructions are intended to ensure that the user can use the product correctly to avoid danger or property loss.

The precaution measure is divided into “Warnings” and “Cautions.”

**Warnings:** Serious injury or death may occur if any of the warnings are neglected.

**Cautions:** Injury or equipment damage may occur if any of the cautions are neglected.

	
<b>Warnings</b> Follow these safeguards to prevent serious injury or death.	<b>Cautions</b> Follow these precautions to prevent potential injury or material damage.



### 1.1.6 Warnings

- In the use of the device, you must be in strict compliance with the electrical safety regulations of the nation and region.
- Input voltage should meet both the SELV (Safety Extra Low Voltage) and the Limited Power Source with 12 VDC according to the IEC60950-1 standard. Refer to technical specifications for detailed information.
- The camera is powered by the external DC power supply (12 VDC, 1 A) that complies with the LPS, and the output current of this external DC power supply must be no more than 6 A.
- Do not connect multiple devices to one power adapter to avoid over-heating or a fire hazard caused by overload.
- Make sure that the plug is firmly connected to the power socket.
- Make sure that the device is firmly fixed if wall mounting or ceiling mounting is adopted.
- If smoke, odor, or noise rise from the device, turn off the power at once and unplug the power cord, and then contact the service center.
- Never attempt to disassemble the camera by unprofessional personal.



### 1.1.7 Cautions

- Do not drop the camera or subject it to physical shock.
- Do not touch sensor modules with fingers.
- Do not place the camera in extremely hot, cold (the operating temperature shall be  $-40^{\circ}$  to  $60^{\circ}$  C), dusty or damp locations, and do not expose it to high electromagnetic radiation.
- If cleaning is necessary, use a clean cloth with a bit of ethanol, and wipe it gently.
- Do not aim the camera at the sun or extra bright places.
- The sensor may be burned out by a laser beam, so when any laser equipment is in using, make sure that the sensor surface will not be exposed to the laser beam.
- Do not expose the device to high electromagnetic radiation or extremely hot, cold, dusty, or damp environments.
- To avoid heat accumulation, good ventilation is required for the operating environment.
- Keep the camera away from liquid while in use for non-waterproof devices.
- While in delivery, the camera shall be packed in its original packing, or packing of the same material.

## 1.1.8 Mark Description

Table 0-1 Mark Description

Mark	Description
---	DC Voltage

# 2 Introduction

## 2.1 Product Features

The camera is applicable for both indoor and outdoor conditions. Application scenarios include roads, warehouses, underground parking lots, bars, etc..

The main features are as follows:

- 8 MP high performance CMOS sensor
- IR cut filter with auto switch
- OSD menu with configurable parameters
- Auto white balance
- internal synchronization
- SMART IR mode
- 3-axis adjustment

## 2.2 Overview

This manual applies to two types of bullet cameras. The overviews of each type are shown in the figures below.

### 2.2.1 Overview of Type I Camera

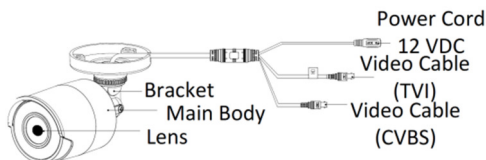

Figure 1 Overview of Type I Camera

### 2.2.1 Overview of Type II Camera

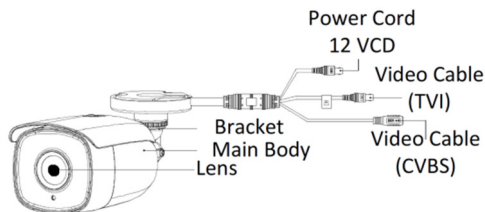

Figure 2 Overview of Type II Camera

# 3 Installation

### Before you start:

- Make sure that the device in the package is in good condition and all the assembly parts are included.
- Make sure that all the related equipment is powered off during the installation.

- Check the specification of the products for the installation environment.
- Check whether the power supply matches your power output to avoid the damage.
- Make sure the wall is strong enough to withstand three times the weight of the camera and the mount.
- If the wall is cement, insert expansion bolts before installing the camera. If the wall is wooden, use self-tapping screws to secure the camera.
- If the product does not function properly, contact your dealer or the nearest service center. Do NOT disassemble the camera for repair or maintenance by yourself.

### 3.1 Installation of Type I Camera

#### 3.1.1 Ceiling/Wall Mounting without Junction Box

##### Steps:

1. Paste the drill template (supplied) where you want to install the camera.
2. Drill the screw holes and the cable hole (optional) in the ceiling/wall according to the drill template.

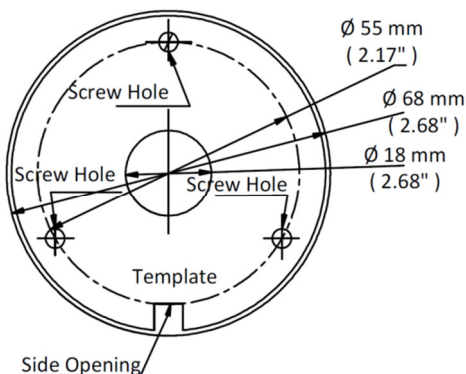

Figure 3 Drill Template

##### Note:

Drill the cable hole when using the ceiling outlet to route the cable.

3. Attach the bracket to the ceiling/wall and secure the camera with supplied screws.

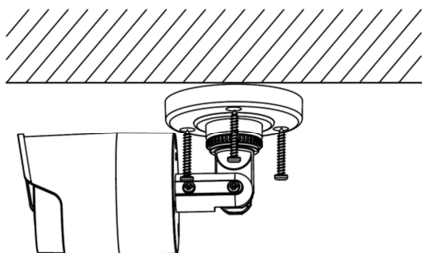

Figure 4 Fix the Camera to the Ceiling

**Note:**

- The supplied screw package contains self-tapping screws and expansion bolts.
  - For cement wall/ceiling, expansion bolts are required to fix the camera. For wooden wall/ceiling, self-tapping screws are required.
4. Route the cables through the cable hole or the side opening.
  5. Connect the corresponding power cord and video cable.
  6. Power on the camera to check if the image on the monitor is at an optimum angle. If not, adjust the camera according to the figure below to get an optimum angle.

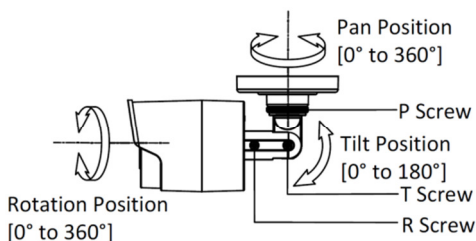

Figure 5 3-axis Adjustment

- 1). Loosen the P screw to adjust the pan position [0° to 360°]. Tighten the screw after completing the adjustment.
- 2). Loosen the T screw to adjust the tilt position [0° to 180°]. Tighten the screw after completing the adjustment.
- 3). Loosen the R screw and rotate the camera [0° to 360°]. Tighten the screw after completing the adjustment.

### 3.1.2 Ceiling/Wall Mounting with Junction Box

**Before you start:**

You need to purchase a junction box separately.

**Steps:**

1. Paste the drill template on the ceiling/wall.
2. Drill screw holes, and the cable hole (optional) in the ceiling/wall according to the holes of the drill template.

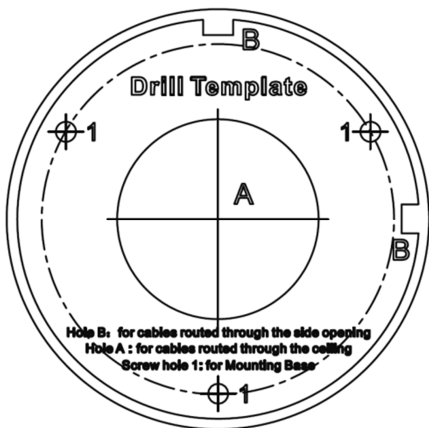

Figure 6 Drill Template of Junction Box

**Note:**

Drill the cable hole when using the ceiling outlet to route the cable.

3. Take apart the junction box, and align the screw holes of the bullet camera with those on the Junction box cover.
4. Fix the camera on the junction box's cover with supplied screws.

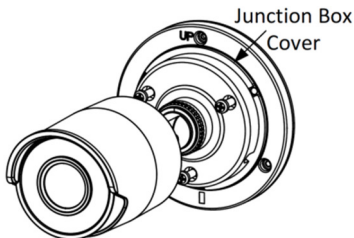

Figure 7 Fix the Camera on the Junction Box Cover

5. Attach the junction box body to the ceiling/wall by aligning the screw holes of the junction box.
6. Secure the junction box body with supplied screws on the ceiling/wall.

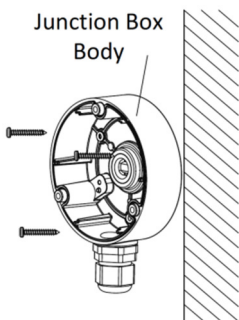

Figure 8 Fix the Junction Box to the Wall/Ceiling

7. Route the cables through the bottom cable hole (optional) or the side cable hole of the junction box.
8. Combine the junction box cover with its body.

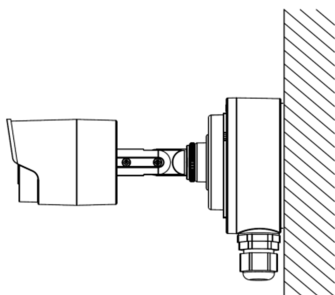

Figure 9 Fix the Junction Box Cover Back to its Body

9. Repeat the step 5 and 6 of *2.1.1 Ceiling/Wall Mounting without Junction Box* to complete the installation.

## 3.2 Installation of Type II Camera

### 3.2.1 Ceiling/Wall Mounting without Junction Box

#### Steps:

1. Paste the drill template (supplied) to the place where you want to install the camera.
2. Drill the screw holes according to the drill template and the cable hole (optional) on the ceiling/wall.

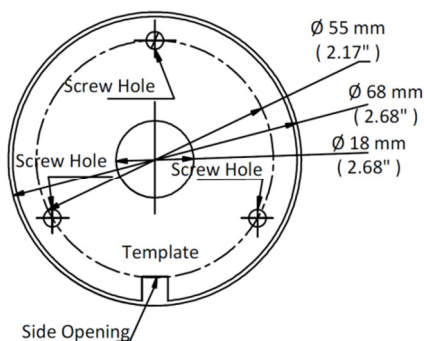

Figure 10 Drill Template

#### Note:

Drill the cable hole in the center of the drill template when using ceiling outlet to route the cable.

3. Route the cables through the cable hole (optional) or the side opening.
4. Fix the camera to the ceiling with supplied screws.



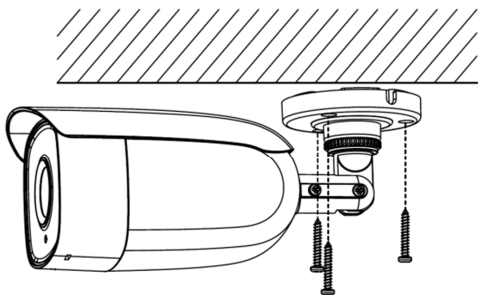

Figure 11 Fix the Camera to the Ceiling

**Note:**

- The supplied screw package contains self-tapping screws, and expansion bolts.
  - For cement wall/ceiling, expansion bolts are required to fix the camera. For wooden wall/ceiling, self-tapping screws are required.
5. Connect the corresponding power cord and video cable.
  6. Power on the camera to check if the image on the monitor is at an optimum angle. If not, adjust the surveillance angle.

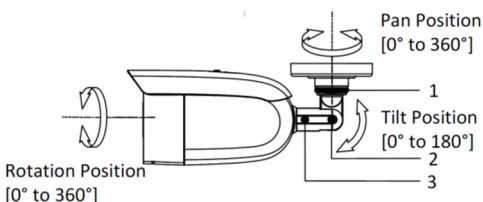

Figure 12 3-Axis Adjustment

- 1). Loosen the No.1 adjusting screw to adjust the pan position [0° to 360°]. Tighten the No.1 adjusting screw.
- 2). Loosen the No.2 adjusting screw to adjust the tilting position [0° to 180°]. Tighten the No. 2 adjusting screw.
- 3). Loosen the No.3 adjusting screw to adjust the rotation position [0° to 360°]. Tighten the No.3 adjusting screw.

### 3.2.2 Ceiling/Wall Mounting with Junction Box

**Before you start:**

You need to purchase a junction box separately.

**Steps:**

1. Paste the drill template on the ceiling/wall.
2. Drill screw holes and the cable hole (optional) in the ceiling/wall according to the holes of the drill template.

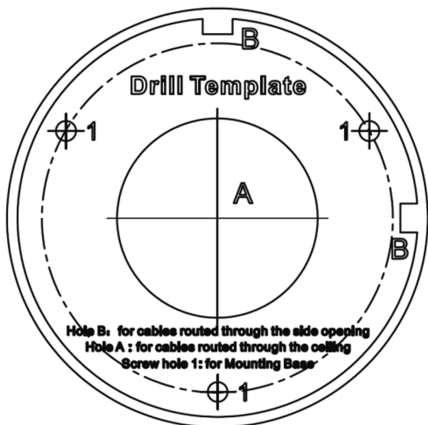

Figure 13 Drill Template

**Note:**

Drill the cable hole, when adopting ceiling outlet to route the cable.

3. Take apart the junction box, and align the screw holes of the bullet camera with those on the Junction box's cover.
4. Fix the camera on the junction box cover with three supplied screws.

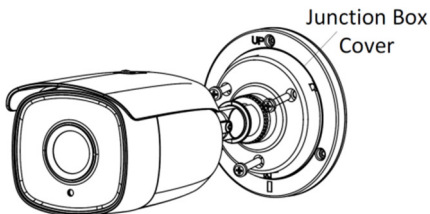

Figure 14 Fix the Camera on the Junction Box Cover

5. Secure the junction box's body with supplied screws on the ceiling/wall.

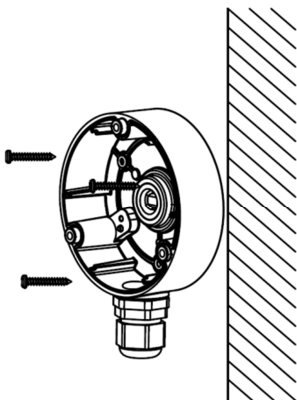

Figure 15 Install the Junction Box

- Route the cables through the bottom cable hole or the side cable hole of the junction box.
- Combine the junction box cover with its body with supplied screws on the junction box cover.

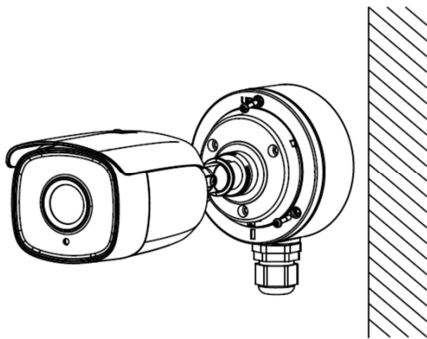



Figure 16 Combine the Junction Box's Cover with its Body

- Repeat step 5 and 6 of 2.2.1 *Ceiling/Wall Mounting without Junction Box* to complete the installation.

## 4 Menu Description

---

### **Purpose:**

Call the menu by clicking button  on the PTZ Control interface, or call preset No.95.

### **Steps:**

- Connect the camera to the TVI DVR and the monitor, as shown below.

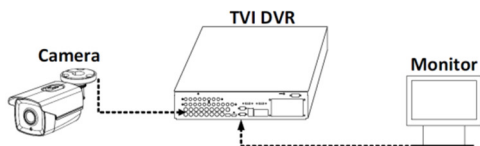



Figure 17 Connection

- Power on the analog camera, TVI DVR, and the monitor to view the image on the monitor.
- Click PTZ Control to enter the PTZ Control interface.
- Call the camera menu by clicking the  button, or call preset No. 95.

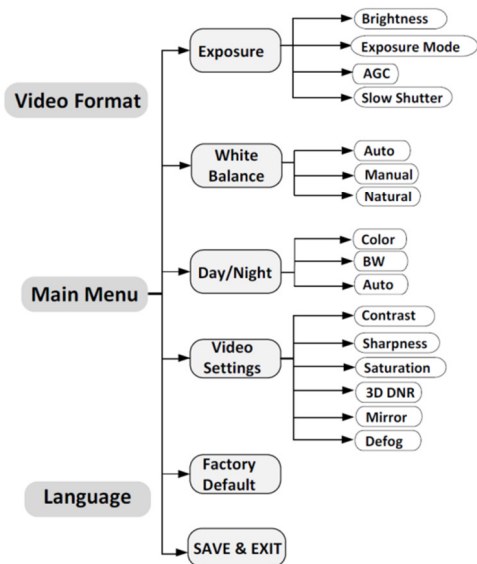

Figure 18 Main Menu Overview

5. Click the direction arrow to control the camera.
  - 1). Click up/down direction button to select the item.
  - 2). Click Iris + to confirm the selection.
  - 3). Click left/right direction button to adjust the value of the selected item.

## 4.1 Video Format

You can set frame rate as 8 MP @ 12.5 fps, 8 MP @ 15 fps, 5 MP @ 20 fps, 4 MP @ 25 fps, 4 MP @ 30 fps, 1080p @ 25 fps, or 1080p @ 30 fps.

## 4.2 Language

Supports English.

## 4.3 Settings

### 4.3.1 Exposure

Exposure describes the brightness-related parameters, which can be adjusted by **Brightness**, **Exposure Mode**, **AGC**, and **Slow Shutter**.

Exposure	
Brightness	<5>
Exposure Mode	<Global>
AGC	<High>
Slow Shutter	<Off>
Back	Save & Exit

Figure 19 Exposure

- **Brightness**

Brightness refers to the brightness of the image.

You can set the brightness value from 1 to 10 to darken or brighten the image. The higher the value, the brighter the image.

- **Exposure Mode**

You can set the **Exposure Mode** as **Global**, **BLC**, **HLC**, and **WDR**.

- **Global**

Global refers to the normal exposure mode which adjusts lighting distribution, variations, and non-standard processing.

- **BLC (Backlight Compensation)**

BLC (Backlight Compensation) compensates light to the object in the front to make it clear, but this may cause the over-exposure of the background where the light is strong.

- **HLC (High Light Compensation)**

HLC (High Light Compensation) masks strong light sources that usually flare across a scene. This makes it possible to see the detail of the image that would normally be hidden.

- **WDR (Wide Dynamic Range)**

The wide dynamic range helps the camera provide clear images even under backlight circumstances. WDR balances the brightness level of the whole image and provides clear images with details.

When WDR is selected as the exposure mode, you can set it as low, medium, high, or off.

- **AGC (Automatic Gain Control)**

It optimizes the clarity of the image in poor light conditions. The **AGC** level can be set as **High**, **Medium**, or **Low**. Select **Off** to disable the **AGC** function.

## Note:

The noise will be amplified when the AGC is on.

- **Slow Shutter**

Slow Shutter increases the exposure time on a single frame, which makes a camera more sensitive to light. Therefore, it can produce images even under low lux conditions. You can set the **Slow Shutter** as Off, x2, x4 under 8 MP @ 15 fps, or 8 MP @ 12.5 fps mode, and as Off, x2, x4, x6, x8, or x16 under other modes according to different light conditions.

### 4.3.2 WB (White Balance)

White balance, the white rendition function of the camera, is to adjust the color temperature according to the environment. It can remove unrealistic color casts in the image. You can set WB mode as **Auto**, **Manual**, or **Natural**.

- **Auto**

Under **Auto** mode, white balance is being adjusted automatically according to the color temperature of the scene illumination.

- **Manual**

Click Iris+ to enter the submenu, you can set the **R Gain/B Gain** value from 1 to 255 to adjust the shades of red/blue color of the image.

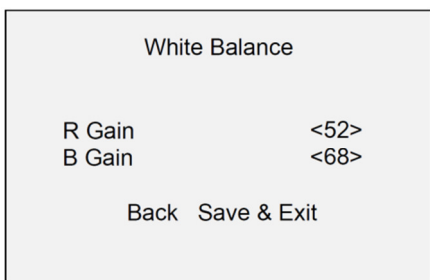

Figure 20 White Balance

- **Natural**

Set the white balance as the **Natural** mode, when large part of the monitoring scene is monochrome.

### 4.3.3 Day Night

**Color**, **BW** (Black White), and **AUTO** are selectable for DAY and NIGHT switches.

- **Color**

The image is colored in day mode all the time.

- **B/W**

The image is black and white all the time, and the IR light turns on in the poor light conditions.

- **Auto**

The image switches from color to B/W, or from B/W to color automatically according to the light conditions.

Click Iris+ to enter the submenu, you can turn on/off the **IR Light** and set the value of **Smart IR** in this menu.

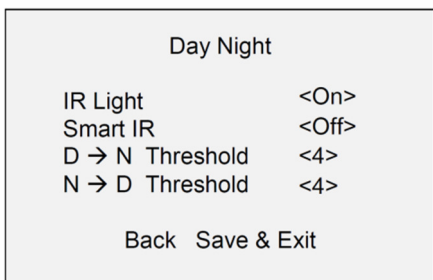

Figure 21 Day Night

- **IR Light**

You can turn on/off the IR Light to meet the requirements of different circumstances.

- **Smart IR**

The **Smart IR** function is used to adjust the light to its most suitable intensity, and prevent the image from over exposure. You can turn on/off this function.

- **D→ N Threshold (Day to Night Threshold)**

**Day to Night Threshold** is used to control the sensitivity of switching the day mode to the night mode. You can set the value from 1 to 9. The larger the value is, the more sensitive the camera is.

- **N→ D Threshold (Night to Day Threshold)**

**Night to Day Threshold** is used to control the sensitivity of switching the night mode to the day mode. You can set the value from 1 to 9. The larger the value is, the more sensitive the camera is.

#### 4.3.4 Video Settings

Move the cursor to **Video Settings** and click Iris+ to enter the submenu. **Contrast**, **Sharpness**, **Saturation**, **3D DNR**, **Mirror**, and **Defog** are adjustable.

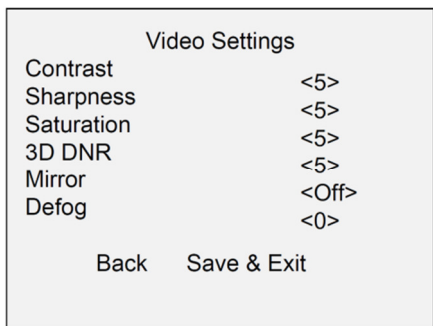

Figure 22 Video Settings

- **Contrast**

This feature enhances the difference in color and light between parts of an image. You can set the **Contrast** value from 1 to 10.

- **Sharpness**

Sharpness determines the amount of detail an imaging system can reproduce. You can set the **Sharpness** value from 1 to 10.

- **Saturation**

Adjust this feature to change the saturation of the color. The value ranges from 1 to 10.

- **3D DNR (Digital Noise Reduction)**

The 3D DNR function can decrease the noise effect, especially when capturing moving images in poor light conditions, and deliver more accurate and sharp image quality. You can set the **3D DNR** value from 1 to 10.

- **Mirror**

**Off**, **H**, **V**, and **HV** are selectable for mirror.

**Off**: The mirror function is disabled. **H**: The image flips 180° horizontally. **V**: The image flips 180° vertically.

**HV**: The image flips 180° both horizontally and vertically.

- **Defog**

It is used in special environments such as foggy or rainy weather, or in high illumination conditions, in which the dynamic range is lower than that in an ordinary environment and the image appears hazy.

Enabling the defog function can enhance subtle details to display clear images.

#### **4.4 Factory Default**

Click **Iris+** to enter the submenu, and click **OK** to reset all the settings to the factory default. Click **Cancel** to give up the reset settings.

#### **4.5 Save & Exit**

Move the cursor to **Save & Exit**, and click **Iris+** to save the settings and exit the menu.