

**HIKVISION®**



# **DS-2CC12D8T-AMM**

## **"Casino" D8T Box Camera**

User Manual

## **Disclaimer**

Copyright © 2018 Hangzhou Hikvision Digital Technology Co., Ltd. ALL RIGHTS RESERVED.

Any and all information, including, among others, wordings, pictures, and graphs are the properties of Hangzhou Hikvision Digital Technology Co., Ltd., or its subsidiaries (hereinafter referred to be "Hikvision"). This user manual (hereinafter referred to be "the Manual") cannot be reproduced, changed, translated, or distributed, partially or wholly, by any means, without the prior written permission of Hikvision. Unless otherwise stipulated, Hikvision does not make any warranties, guarantees, or representations, express or implied, regarding the Manual.

## **Introduction**

Thank you for purchasing our product. If there are any questions or requests, do not hesitate to contact the dealer.

This manual may contain technically incorrect information or printing errors, and the content is subject to change without notice. This manual will be updated as needed. We will readily improve or update the products or procedures described in the manual.

## **Regulatory Information**

### **FCC Information**

Please take attention that changes or modifications not expressly approved by the party responsible for compliance could void the user's authority to operate the equipment.

### **FCC Compliance**

This equipment has been tested and found to comply with the limits for a Class B digital device, pursuant to part 15 of the FCC Rules. These limits are designed to provide reasonable protection against harmful interference in a residential installation. This equipment generates, uses, and can radiate radio frequency energy and, if not installed and used in accordance with the instructions, may cause harmful interference to radio communications. However, there is no guarantee that interference will not occur in a particular installation. If this equipment does cause harmful interference to radio or television reception, which can be determined by turning the equipment off and on, the user is encouraged to try to correct the interference by one or more of the following measures:

- Reorient or relocate the receiving antenna.
- Increase the separation between the equipment and the receiver.

- Connect the equipment to an outlet on a circuit different from that to which the receiver is connected.
- Consult the dealer or an experienced radio/TV technician for help.

## FCC Conditions

This device complies with part 15 of the FCC Rules. Operation is subject to the following two conditions:

1. This device may not cause harmful interference.
2. This device must accept any interference received, including interference that may cause undesired operation.

## EU Conformity Statement



This product and, if applicable, the supplied accessories too are marked with "CE" and comply therefore with the applicable harmonized European standards listed under the Low Voltage Directive 2014/35/EU, the EMC Directive 2014/30/EU, the RoHS Directive 2011/65/EU.



**2012/19/EU (WEEE Directive):** Products marked with this symbol cannot be disposed of as unsorted municipal waste in the European Union. For proper recycling, return this product to your local supplier upon the purchase of equivalent new equipment, or dispose of it at designated collection points. For more information see: [www.recyclethis.info](http://www.recyclethis.info).



**2006/66/EC (Battery Directive):** This product contains a battery that cannot be disposed of as unsorted municipal waste in the European Union. See the product documentation for specific battery information. The battery is marked with this symbol, which may include lettering to indicate cadmium (Cd), lead (Pb), or mercury (Hg). For proper recycling, return the battery to your supplier or to a designated collection point. For more information see: [www.recyclethis.info](http://www.recyclethis.info).

## Industry Canada ICES-003 Compliance

This device meets the CAN ICES-3 (B)/NMB-3(B) standards requirements.



## Safety Instruction

These instructions are intended to ensure that the user can use the product correctly to avoid danger or property loss.

The precaution measure is divided into "Warnings" and "Cautions."

**Warnings:** Serious injury or death may occur if any of the warnings are neglected.

**Cautions:** Injury or equipment damage may occur if any of the cautions are neglected.

	
<b>Warnings</b> Follow these safeguards to prevent serious injury or death.	<b>Cautions</b> Follow these precautions to prevent potential injury or material damage.

 **Warnings**

- In the use of the device, you must be in strict compliance with the electrical safety regulations of the nation and region.
- Input voltage should meet both the SELV (Safety Extra Low Voltage) and the Limited Power Source with 12 VDC according to the IEC60950-1 standard. Refer to technical specifications for detailed information.
- Do not connect multiple devices to one power adapter to avoid overheating or a fire hazard caused by overload.
- Make sure that the plug is firmly connected to the power socket.
- Make sure that the device is firmly fixed if wall mounting or ceiling mounting is adopted.
- If smoke, odor, or noise rise from the device, turn off the power at once, unplug the power cord, then contact the service center.
- Never attempt to disassemble the camera by unprofessional personal.

 **Cautions**

- Do not drop the camera or subject it to physical shock.
- Do not place the camera in extremely hot, cold (the operating temperature shall be -40° to 60° C), dusty, or damp locations, and do not expose it to high electromagnetic radiation.
- Do not touch sensor modules with fingers.
- If cleaning is necessary, use clean cloth with a bit of ethanol and wipe it gently.
- Do not aim the camera at the sun or extra bright places.

- The sensor may be burned out by a laser beam, so if any laser equipment is in use, make sure that the sensor surface will not be exposed to the laser beam.
- Do not expose the device to high electromagnetic radiation or extremely hot, cold, dusty, or damp environments.
- To avoid heat accumulation, good ventilation is required for the operating environment.
- Keep the camera away from liquid while in use for non-waterproof device.
- While in delivery, the camera shall be packed in its original packing or similar materials.

## Mark Description

**Table 1** Mark Description

Mark	Description
==	DC Voltage
~	AC Voltage

# Contents

---

1	Introduction.....	8
1.1	Product Features.....	8
1.2	Overview.....	8
2	Installation.....	9
2.1	Installation Preparation .....	9
2.1.1	Before You Start.....	9
2.2	Installing the Lens.....	9
2.2.1	Before You Start.....	9
3	Menu Description .....	11
3.1	FORMAT.....	13
3.2	LANGUAGE.....	13
3.3	MAIN MENU.....	13
3.3.2	AE (AUTO EXPOSURE) .....	13
3.3.2.1	LENS .....	13
3.3.2.2	SHUTTER.....	14
3.3.2.3	BRIGHTNESS.....	14
3.3.2.4	EXPOSURE MODE.....	14
3.3.2.5	AGC (Auto Gain Control).....	15
3.3.2.6	SENSE UP.....	15
3.3.3	WB (White Balance).....	15
3.3.3.1	ATW (Auto Tracking White Balance) .....	15
3.3.3.2	MWB (Manual White Balance).....	15
3.3.4	DAY/NIGHT.....	16
3.3.4.1	COLOR.....	16
3.3.4.2	B/W .....	16
3.3.4.3	AUTO .....	16
3.3.5	VIDEO SETTING.....	17
3.3.5.1	CONTRAST.....	17
3.3.5.2	SHARPNESS .....	17
3.3.5.3	COLOR GAIN.....	17

3.3.5.4 3D DNR (Digital Noise Reduction) .....	17
3.3.5.5 MIRROR .....	17
3.3.6 FUNC (Functions).....	18
3.3.7 SAVE & EXIT .....	20

# 1 Introduction

## 1.1 Product Features

The camera is applicable for indoor conditions. The main features are as follows:

- High performance CMOS sensor
- Low illumination: 0.005 lux @ (f/1.2, AGC on)
- Auto gain control
- 120 dB true WDR
- OSD menu
- Internal synchronization

## 1.2 Overview

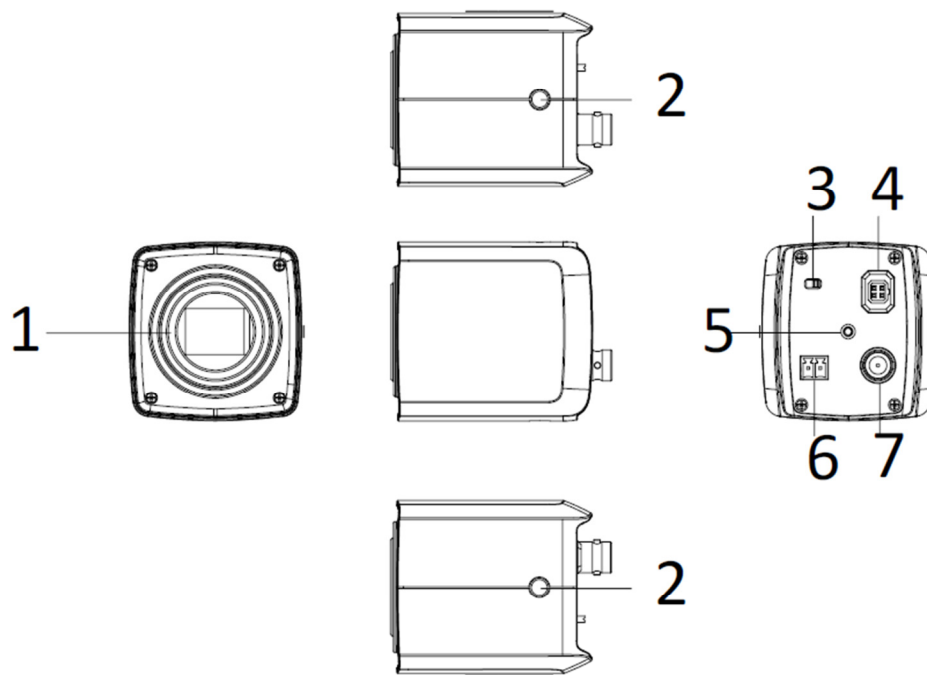

Figure 1, Box Camera's Overview

**Table 2** Box Camera Description

No.	Description	No.	Description
1	Lens Interface	2	Lock Screw
3	Dial Switch	4	Lens Socket
5	GND	6	Power Interface
7	Video Interface		



## 2 Installation

---

### 2.1 Installation Preparation

#### 2.1.1 Before You Start

- Make sure that the device in the package is in good condition and all the assembly parts are included.
- Make sure that all the related equipment is powered-off during the installation.
- Check the specification of the products for the installation environment.
- Check whether the power supply matches your required output to avoid damage.
- Make sure the wall is strong enough to withstand three times the weight of the camera and the bracket.
- If the wall is concrete, insert expansion screws before installing the camera. If the wall is wood, use self-tapping screws to secure the camera.
- If the product does not work properly, contact your dealer or the nearest service center. Do NOT disassemble the camera for repair or maintenance yourself.

### 2.2 Installing the Lens

#### 2.2.1 Before You Start

Lens must be purchased separately.

1. Rotate the lens clockwise onto the camera module tightly.

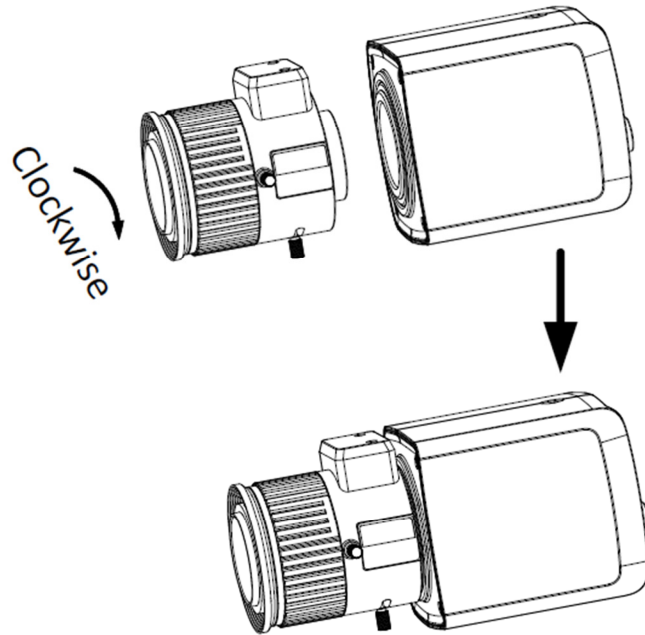



Figure 2, Installing the Lens

2. Insert the cable attached on the lens to the lens socket to finish the lens installation.
3. Connect the corresponding power cord and video cable.
4. Power on the camera to view the image on the monitor.

**NOTE:** Do not remove the cable attached to the lens while power is on.

## 3 Menu Description

---

Call the menu by clicking the  icon on the PTZ Control interface, or call preset no.95.

1. Connect the camera to the TVI DVR and the monitor, as shown below.

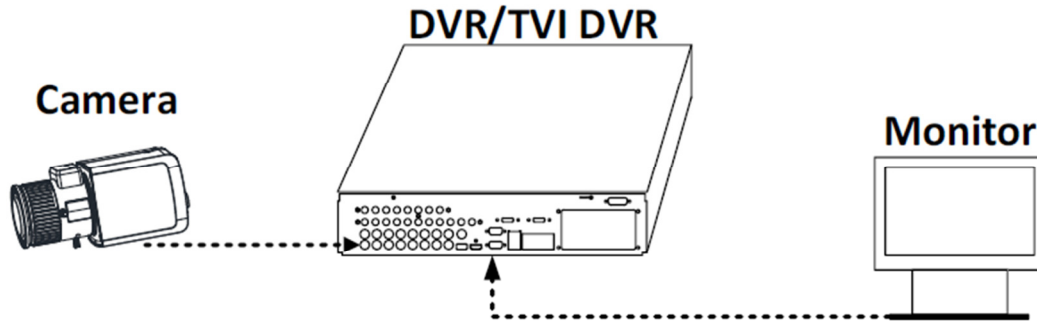



Figure 3, Connection

2. Power on the analog camera, TVI DVR, and the monitor to view the image on the monitor.
3. Click **PTZ Control** to enter the PTZ Control interface.
4. Call the camera menu by clicking the  icon, or call preset no. 95.

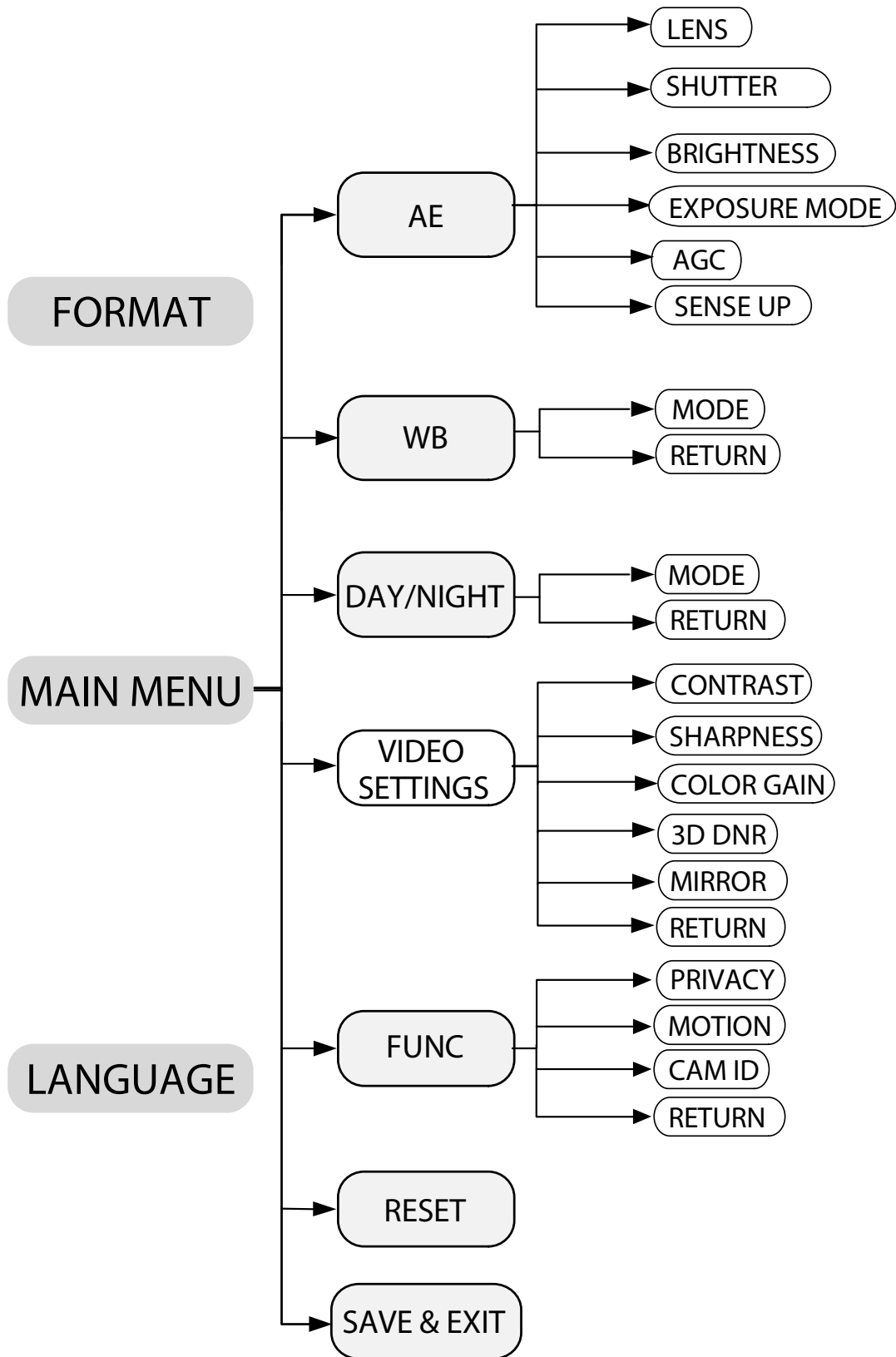

Figure 4, Main Menu Overview

5. Click the direction arrow to control the camera.

(1) Click the **Up/Down** direction button to select the item.

(2) Click **Iris+** to confirm the selection.

(3) Click the left/right direction button to adjust the value of the selected item.

### 3.1 FORMAT

#### PAL (Phase Alternating Lines)

PAL is a color encoding system for analog televisions used in broadcast television systems in most countries.

#### NTSC: (National Television System Committee)

NTSC is the analog television system that is used in most of North America, parts of South America, Myanmar, South Korea, etc.

### 3.2 LANGUAGE

Supports English and Chinese.

### 3.3 MAIN MENU

#### 3.3.2 AE (AUTO EXPOSURE)

**Auto Exposure** describes the brightness-related parameters, which can be adjusted by **LENS**, **SHUTTER**, **BRIGHTNESS**, **EXPOSURE MODE**, **AGC**, and **SENSE UP**.

EXPOSURE	
LENS	◀ MANUAL ▶
SHUTTER	◀ AUTO ▶
BRIGHTNESS	◀ 5 ▶
EXPOSURE MODE	◀ GLOBAL ▶
AGC	◀ MIDDLE ▶
SENSE UP	◀ 0 ▶
RETURN	

Figure 5, AE

##### 3.3.2.1 LENS

**MANUAL** and **DC** modes are selectable.

- **MANUAL:** You can control the iris manually.

- **DC:** Iris is automatically controlled.

### 3.3.2.2 SHUTTER

**Shutter** denotes the speed of the shutter.

- **Under LENS MANUAL Mode** – Only AUTO is available, which means the shutter speed is controlled automatically.
- **Under LENS DC Mode**
  - > **PAL:** 1/25 s, 1/50 s, FLK 1/200 s 1/400 s, 1/1K s, 1/2K s, 1/10K s, and 1/50K s are available.
  - > **NTSC:** 1/30 s, 1/60 s, FLK, 1/240s, 1/480 s, 1/1K s, 1/2K s, 1/10K s, and 1/50K s are available.

### 3.3.2.3 BRIGHTNESS

Brightness refers to the brightness of the image.

You can set the brightness value from 1 to 10 to darken or brighten the image. The higher the value, the brighter the image.

### 3.3.2.4 EXPOSURE MODE

You can set the **EXPOSURE MODE** to **GLOBAL**, **BLC**, or **WDR**.

- **GLOBAL**

**GLOBAL** refers to the normal exposure mode, which adjusts lighting distribution, variations, and non-standard processing.

- **BLC (Backlight Compensation)**

**BLC** compensates light to the object in the front to make it clear, but may cause overexposure of the background where the light is strong.

When **BLC** is selected as the exposure mode, the BLC level can be adjusted from 0 to 8.

- **WDR (Wide Dynamic Range)**

**WDR** helps the camera provide clear images even under

backlit circumstances. **WDR** balances the brightness level of the whole image and provides clear images with details.

### 3.3.2.5 AGC (Auto Gain Control)

**AGC** optimizes the clarity of the image in poor light conditions. The **GAIN** level can be set to **HIGH**, **MIDDLE**, or **LOW**. Select **OFF** to disable the **GAIN** function.

**NOTE:** The noise will be amplified when the **GAIN** is on.

### 3.3.2.6 SENSE UP

**Sense Up** increases the exposure on a signal frame, which makes a camera more sensitive to light, so it can produce images even in low lux conditions. You can set the **SENS-UP** to **OFF** or **AUTO**, according to the light conditions.

The **SENS-UP** function will automatically adjust itself to x2, x4, x6, x8, x10, x12, x14, and x16 according to the light conditions.

## 3.3.3 WB (White Balance)

**WB**, the white rendition function of the camera, is to adjust the color temperature according to the environment. It can remove unrealistic color casts in the image. You can set WB mode to **ATW** or **MWB**.

### 3.3.3.1 ATW (Auto Tracking White Balance)

Under **ATW** mode, white balance is adjusted automatically according to the color temperature of the scene illumination.

### 3.3.3.2 MWB (Manual White Balance)

You can set the **R GAIN/B GAIN** value from 1 to 255 to adjust the image red/blue shades.

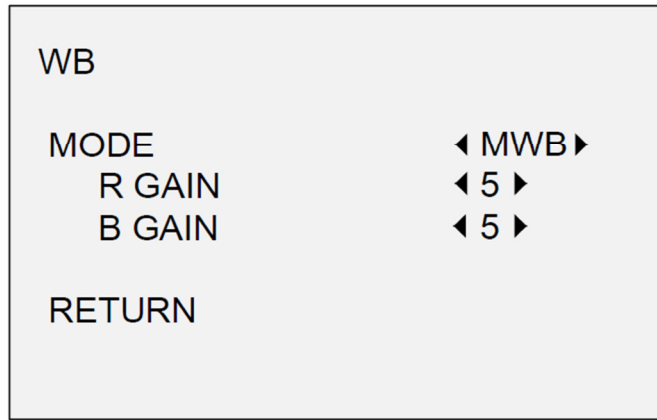

Figure 6, MWB Mode

### 3.3.4 DAY/NIGHT

**Color**, **BW (Black and White)**, and **AUTO** are selectable for **DAY/NIGHT** switches.

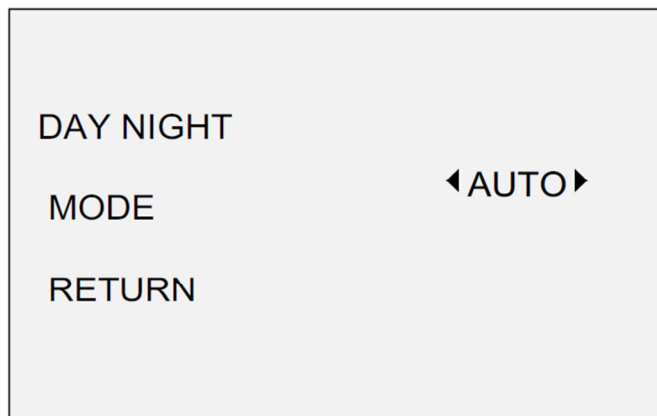

Figure 7, Day/Night

#### 3.3.4.1 COLOR

The image is in color in day mode all the time.

#### 3.3.4.2 B/W

The image is black and white all the time.

#### 3.3.4.3 AUTO

Automatically switches between **Color** and **BW (Black and White)** according to actual scene brightness.



### 3.3.5 VIDEO SETTING

Move the cursor to **VIDEO SETTING** and click **Iris+** to enter the submenu. **CONTRAST**, **SHARPNESS**, **COLOR GAIN**, **3D DNR**, and **MIRROR** are adjustable.

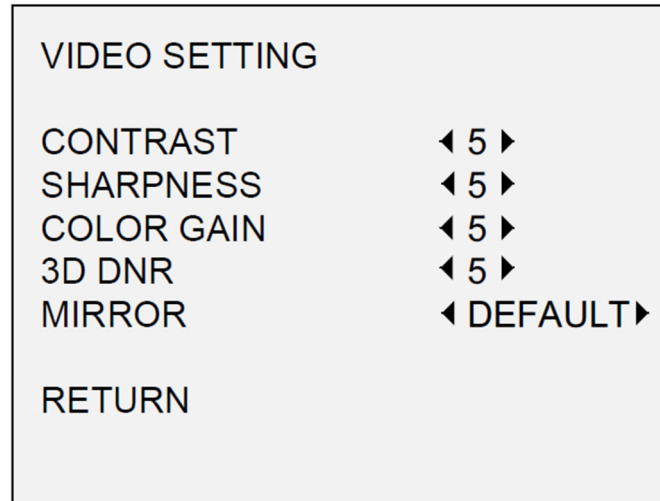

Figure 8, Video Setting

#### 3.3.5.1 CONTRAST

This feature enhances the difference in color and light between parts of an image. You can set the **CONTRAST** value from 1 to 10.

#### 3.3.5.2 SHARPNESS

Sharpness determines the amount of detail an imaging system can reproduce. You can set the **SHARPNESS** value from 1 to 10.

#### 3.3.5.3 COLOR GAIN

Adjust this feature to change the saturation of the color. The value ranges from 1 to 10.

#### 3.3.5.4 3D DNR (Digital Noise Reduction)

The 3D DNR function can decrease the noise effect, especially when capturing moving images in poor light conditions and delivering more accurate and sharp image quality. You can set the **DNR** value from 1 to 10.

#### 3.3.5.5 MIRROR

**DEFAULT**, **H**, **V**, and **HV** are selectable for mirror.

- **DEFAULT:** The mirror function is disabled.
- **H:** The image flips 180° horizontally.
- **V:** The image flips 180° vertically.
- **HV:** The image flips 180° both horizontally and vertically.

### 3.3.6 FUNC (Functions)

In the **FUNC** sub-menu, you can set the camera's **privacy mask**, **motion detection**, **camera ID**, and **DPC**.

- **PRIVACY**

The privacy mask allows you to cover certain areas that you don't want to be viewed or recorded. Up to four privacy areas are configurable.

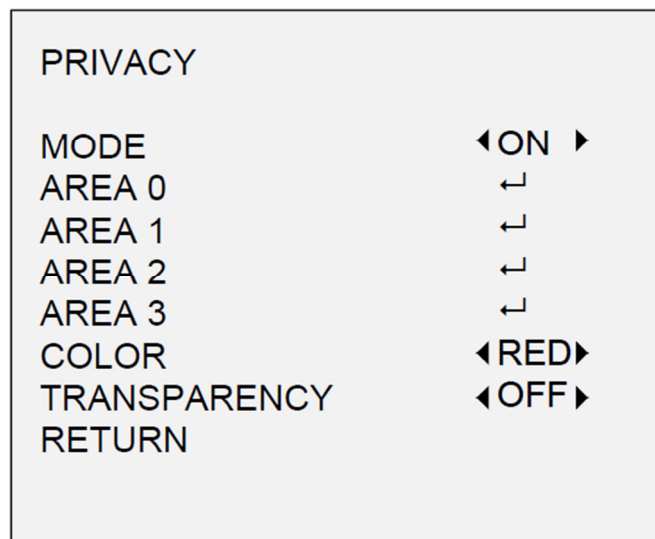

Figure 9, Privacy

Select a **PRIVACY** area. Set the **DISPLAY** status as **ON**. Click the **Up/Down/Left/Down** button to define the area's position and size.

- **MOTION**

In the user-defined motion detection surveillance area, the moving object can be detected and the alarm will be triggered. Up to four motion detection areas can be configured.

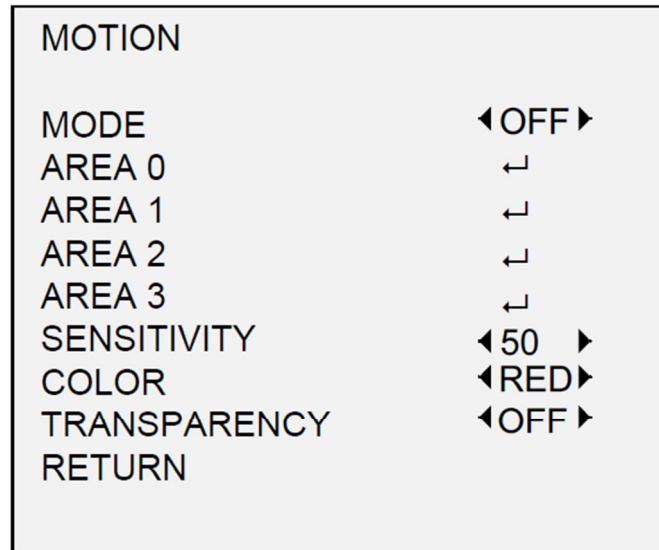

Figure 10, Motion

Select a **MOTION** area. Set the **DISPLAY** status as **ON**. Click the **Up/Down/Left/Right** button to define the position and size of the area. Set the **SENSITIVITY** from 0 to 100.

- **CAMERA ID**

Edit the camera ID in this section.

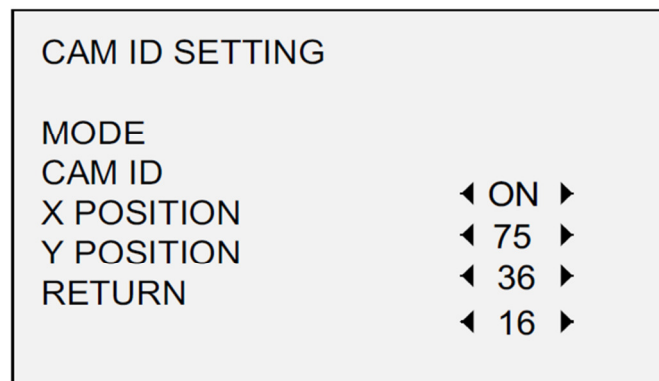

Figure 11, Cam ID Setting

Set the **MODE** to **ON**. Click the **Up/Down/Left/Right** button to choose the camera ID and the position.

- **DPC (Defective Pixel Correction)**

Defective pixels are pixels in a CMOS image sensor that fail to sense light levels correctly. This series of camera supports defective pixel correction.

Set mode **ON** to enable and **OFF** to disable the function.

- **RESET**

Reset all the settings to the defaults.

### **3.3.7 SAVE & EXIT**

Move the cursor to **SAVE & EXIT** and click **Iris+** to save the setting and exit the menu.